

The Effect of Exhaust Gas Recirculation(EGR) on Combustion Stability, Engine Performance and Exhaust Emissions in a Gasoline Engine

Jinyoung Cha, Junhong Kwon, Youngjin Cho, Simsoo Park*

Department of Mechanical Engineering, Korea University, Seoul 136-701, Korea

The EGR system has been widely used to reduce nitrogen oxides (NOx) emission, to improve fuel economy and suppress knock by using the characteristics of charge dilution. However, as the EGR rate at a given engine operating condition increases, the combustion instability increases. The combustion instability increases cyclic variations resulting in the deterioration of engine performance and emissions. Therefore, the optimum EGR rate should be carefully determined in order to obtain the better engine performance and emissions. An experimental study has been performed to investigate the effects of EGR on combustion stability, engine performance, NOx and the other exhaust emissions from 1.5 liter gasoline engine. Operating conditions are selected from the test result of the high speed and high acceleration region of SFTP mode which generates more NOx and needs higher engine speed compared to FTP-75 (Federal Test Procedure) mode. Engine power, fuel consumption and exhaust emissions are measured with various EGR rate. Combustion stability is analyzed by examining the variation of indicated mean effective pressure (COV_{imep}) and the timings of maximum pressure (P_{max}) location using pressure sensor. Engine performance is analyzed by investigating engine power and maximum cylinder pressure and brake specific fuel consumption (BSFC).

Key Words : EGR (Exhaust Gas Recirculation), COV(Coefficient of Variation), IMEP (Indicated Mean Effective Pressure), BSFC(Brake Specific Fuel Consumption), SFTP (Supplemental Federal Test Procedure)

Nomenclature

BMEP : Brake Mean Effective Pressure (kPa)
 BSFC : Brake Specific Fuel Consumption (g/kwh)
 COV_{imep} : Coefficient of Variation of Indicated Mean Effective Pressure (%)
 IMEP : Indicated Mean Effective Pressure (kPa)
 MBT : Minimum Spark Advance for Best Torque (°BTDC)
 P_{max} : Maximum Cylinder Pressure (kPa)

$\theta_{P_{max}}$: Crank Angle of Maximum Cylinder Pressure (°ATDC)
 [CO₂]_{IN} : Intake manifold CO₂ concentration
 [CO₂]_{EX} : Exhaust manifold CO₂ concentration
 [CO₂]_{ATM} : Atmosphere CO₂ concentration
 I.D. : Injection Duration

1. Introduction

As a result of growing interests in air pollution, global demands related to vehicle emission regulations proposed by environmental protection organizations of many countries are increasing. According to these trends, the EPA (Environmental Protection Agency) of United States has proposed revisions to FTP-75 mode

* Corresponding Author,

E-mail : spark@korea.ac.kr

TEL : +82-2-3290-3368; FAX : +82-2-926-9290

Department of Mechanical Engineering, Korea University, 1, 5-Ka, Anam-Dong, Sungbuk-Ku, Seoul 136-701, Korea. (Manuscript Received February 16, 2001; Revised June 1, 2001)

used to evaluate compliance with automotive emission standards for the reflection of real vehicle driving habits.

The SFTP mode, a revision mode, includes high-speed, rapid-acceleration of the vehicle (US06) and operation of air conditioner (SC03). The combination of stoichiometric operation and US06 driving cycle would lead to an increase in the exhaust space velocity by 250 percent over current space velocity, and a catalyst temperature increase of 50~70°C. The use of air conditioning could lead to NOx emission increase of 50~200 percent, depending on the engine power-to-curb weight ratio of the tested vehicle (Duleep and Meszler, 1996; Watson, 1997). The SFTP mode which is more stringent than FTP mode is applied from Model Year 2001.

EPA has suggested the use of increased EGR flow rates as a technology to reduce NOx emission for SFTP, since the use of EGR could reduce NOx emission by lowering maximum cylinder temperature and it is known that the application of EGR prevents knocking and improves fuel economy (Neame *et al.*, 1995). But automobile manufacturers are reluctant to apply EGR system at high load condition because of combustion instability and durability problem of EGR system. However, in the case of direct injection gasoline engines and lean burn engines, conventional three way catalytic converters are limited by the low NOx conversion efficiency under lean operation condition. EGR system has been widely used to reduce raw NOx emission from direct injection gasoline engine and lean burn engine (Hacohen *et al.*, 1995).

When SFTP test has been carried out with engine displacement over 2.0 liter, NOx emission would be within emission regulation with conventional catalytic converter. However, increase of NOx could be a problem for engine displacement less than 1.5 liter.

It is known that increasing EGR rate at part load has much impact on engine stability and exhaust emissions. Application of EGR could reduce NOx emission in a large amount, but it leads to the deterioration of COV_{imep} and the increase of HC and CO emissions (Heywood,

1988) (Han, 2001). As EGR rate increases over a certain value, slow burn and partial burn occur frequently. In the slow-burn cycle, fuel is burned completely, but the brake power of engine decreased by about 50 percent. In case of partial burn cycles, IMEP drops over 50 percent. Especially, in misfiring cycles, IMEP would be negative value. Empirically, it has been found that about 10 percent of COV in IMEP is the engine's stable operating limit, which occurs just before the onset of partial burn cycle. The magnitude of change in the maximum cylinder pressure (P_{max}) and the crank angle of maximum cylinder pressure, $\theta_{P_{max}}$ (ATDC) depends on whether the average burning process is complete or not (Kalghatgi, 1987). In slow burn cycles, retarded spark timing produces little change in P_{max} location ($\theta_{P_{max}}$). However, in fast burn cycles with slightly retarded spark timing, P_{max} location ($\theta_{P_{max}}$) depends essentially on the change of each combustion process and is independent of charging variations (Dai and Davis, 1995).

In this work, the various effects of EGR on combustion stability, engine performance, NOx and the other exhaust emissions from 1.5 liter gasoline engine were investigated experimentally. Engine operating conditions were selected from the test results of SFTP mode and FTP-75 mode.

2. Experiments

2.1 Experimental apparatus

Figure 1 shows the schematic diagram of the experimental apparatus and the general specifications of the test engine are summarized in Table 1.

Table 1 Specification of test engine

Engine Type	I-4, DOHC 16V
Bore (mm)	75.5
Stroke (mm)	83.5
Displacement (cc)	1495
Fuel Injection Type	MPI
Rated Power (PS/rpm)	104/5800
Rated Torque (kg·m/rpm)	14.3/4000

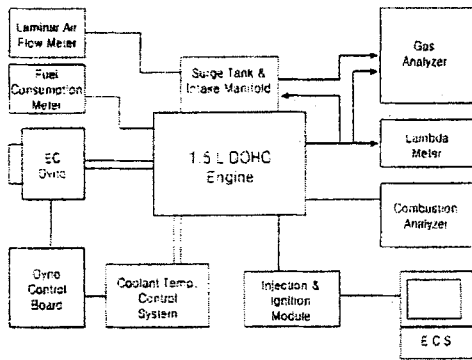

Fig. 1 Schematic diagram of experimental apparatus

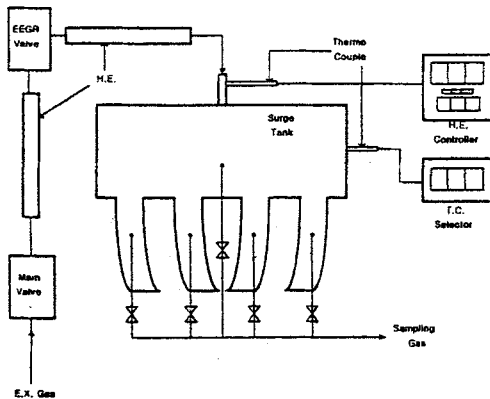

Fig. 2 EGR supply and sampling system

Test engine is an inline, four cylinder, 1.5 liter DOHC spark ignition engine with additional EGR supply, which extends from the exhaust pipe to the top-center of the surge tank. To avoid maldistribution of EGR, the entrance of EGR was positioned between number 2 and number 3 cylinder in the surge tank (Park *et al.*, 1998). EGR rate is calculated by the Eq. (1) with a simultaneous gas sampling from both intake manifold and exhaust pipe individually.

$$\text{EGR rate} = \frac{[\text{CO}_2]_{\text{IN}} - [\text{CO}_2]_{\text{ATM}}}{[\text{CO}_2]_{\text{EX}} - [\text{CO}_2]_{\text{IN}}} \quad (1)$$

The multi-point fuel injection and spark ignition of the test engine are modulated by an ECU that could control fuel injection duration, injection timing and ignition timing properly. Test engine was warmed up to the set temperature (engine coolant temperature : $85 \pm 3^\circ\text{C}$). Engine test conditions were set for engine speed (rpm),

Table 2 Test conditions

rpm	Mode	Time (sec)	Spark Timing ($^\circ\text{BTDC}$)	Injector Duration (msec)
1500	FTP-75	882	27.75	4.40
	FTP-75	537	26.25	6.20
	FTP-75	99	23.25	7.50
1800	FTP-75	288	33.75	4.52
	FTP-75	2348	27.75	5.81
	FTP-75	371	24.75	7.24
2000	FTP-75	659	29.25	4.30
	FTP-75	2003	27.00	6.70
	FTP-75	28	29.00	7.78
2400	FTP-75	254	31.50	5.81
	FTP-75	657	28.50	7.52
	FTP-75	2434	26.25	9.54
2600	SFTP	248	31.50	6.56
	SFTP	265	26.25	8.79
	SFTP	231	24.75	9.33
3000	SFTP	309	29.25	7.63
	SFTP	364	30.00	8.37
	SFTP	415	27.00	9.27

fuel injection duration per cycle, throttle angle and A/F ratio of a selected test point shown in Table 2. A laminar air flow meter was used to measure the amount of intake air and a photo-type fuel consumption meter was used to calculate fuel consumption rate. The exhaust emissions were measured for a change of spark timing at constant interval on each EGR rate. The concentrations of regulated emissions and carbon dioxide were measured at the upstream of the catalytic converter. The cylinder pressure was measured with a pressure sensor mounted in a spark plug holder and analyzed with a combustion analyzer. Cylinder pressure was measured and mean values of maximum cylinder pressure, IMEP, COV_{imep} and $\theta_{P_{\text{max}}}$ could be analyzed with cylinder pressure data measured during 150 cycles.

2.2 Selection of test condition

Figures 3 and 4 show the emission tendency of

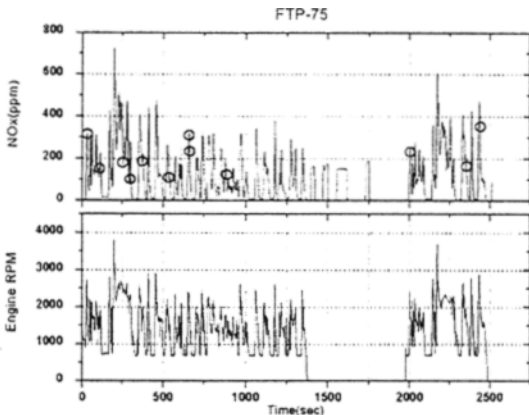

Fig. 3 Profiles of NOx emission and engine speed (rpm) (FTP-75)

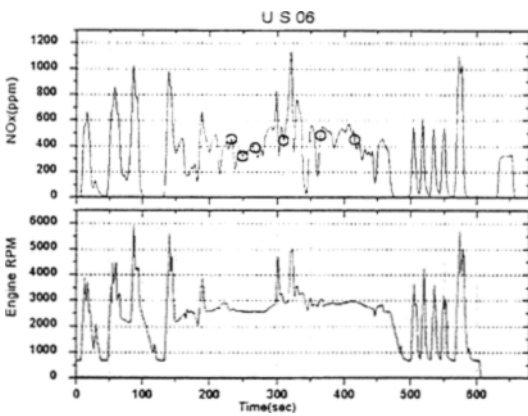

Fig. 4 profiles of NOx emission and engine speed (rpm) (US-06)

NOx and engine speed (rpm) from the SFTP and FTP-75 on-road vehicle mode test. Since NOx measurement includes the dilute air, relative trend could be only taken into consideration. After analyzing the engine mapping data and test mode, test conditions that generate large amount of NOx and frequently occurred are selected. US06 mode, high speed and high acceleration rate test drive of SFTP, shows the higher NOx emission and engine speed (rpm) compared to FTP-75 mode. Therefore, high engine speed (rpm), high load conditions mainly are selected in the US06 mode. Table 2 shows the selected test conditions.

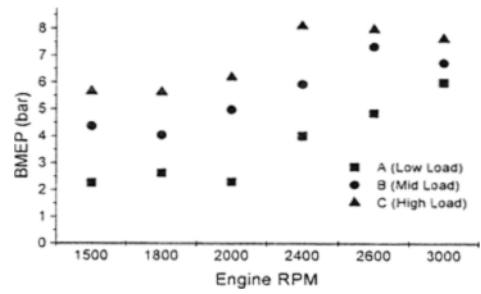

Fig. 5 BMEP of test conditions

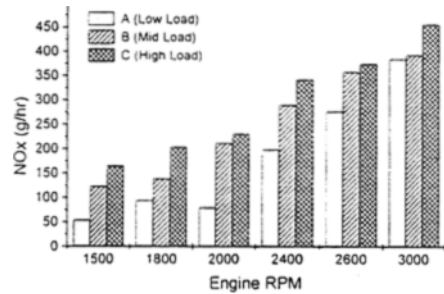

Fig. 6 NOx emission of test conditions

3. Results and Discussion

3.1 Standard engine test

Figures 5 and 6 show BMEP and the NOx emission of standard engine without EGR based on the test condition of Table 2.

The NOx emission increases with increasing level of BMEP and engine speed (rpm). The condition of large amount of emission that frequently occurred needs to be improved by applying EGR.

3.2 EGR test

EGR rate was slowly increased until it is limited to the acceptable COV_{imep} level at each test condition and spark timing was advanced over MBT point. Table 3 shows the test result of reduction rate of BSNOx (Brake specific NOx) emission at the maximum EGR rate compared to that of the standard engine.

Figures 7 and 8 show the trends of BSNOx, BSHC and BSCO according to the spark timing and EGR rate change at 2400 rpm and 3000 rpm.

Table 3 Reduction rate of NOx

rpm	I.D. (msec)	BSNOx (g/kWh, Standard)	BSNOx (g/kWh, Max.EGR)	Reduction Rate (%)	Max. EGR Rate (%)
1500	4.40	12.9	1.6	87.6	24.0
	6.20	15.3	3.2	78.9	24.0
	7.50	16.0	2.2	61.2	20.0
1800	4.52	16.3	1.7	90.0	25.0
	5.81	16.2	3.8	76.3	24.0
2000	4.30	12.4	2.3	81.2	24.0
	6.70	17.3	6.9	60.2	16.0
	7.78	15.6	8.1	47.8	15.0
2400	5.81	17.2	5.2	69.9	19.2
	7.52	16.6	9.4	43.6	12.0
	9.54	14.4	9.9	31.0	8.0
2600	6.56	17.9	7.1	60.1	15.4
	8.79	15.4	10.2	33.8	9.5
	9.33	15.1	11.2	25.4	7.9
3000	7.63	17.5	11.4	34.6	10.1
	8.37	15.9	10.0	37.5	8.0
	9.27	16.3	11.6	28.9	7.6

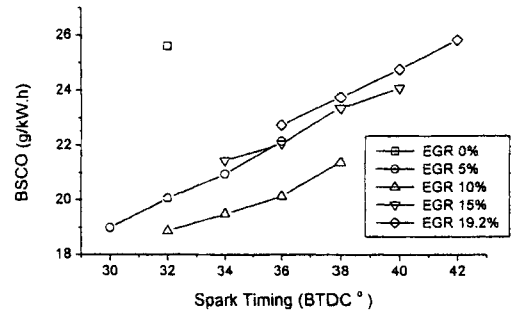
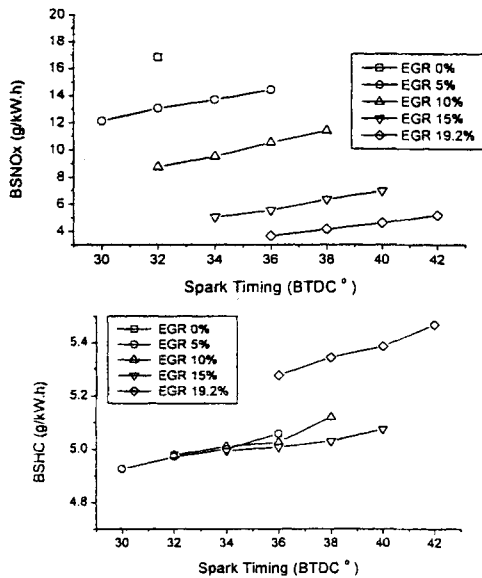

Fig. 7 Effect of EGR rate and Spark timing on Nox, THC and CO emissions (2400rpm, I.D.: 5.81msec)

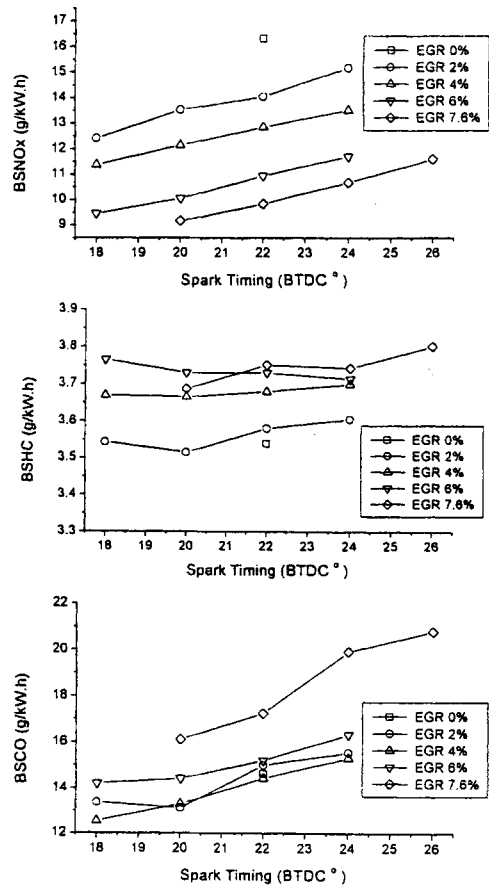

Fig. 8 Effect of EGR rate and Spark Timing on NOx, THC and CO emissions (3000rpm, I.D.: 9.27msec)

In general, the BSNOx emission decreases with increased level of EGR rate from the low engine speed (rpm), load condition to the high engine

speed (rpm), load condition. When combustion condition is unstable with high EGR rate, it leads to the power drop caused by the unstable power

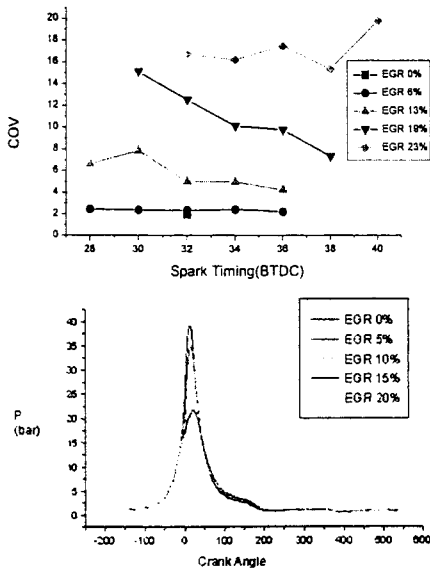

Fig. 9 Effect of EGR rate on COV and cylinder pressure (2400rpm, I.D. : 5.81msec)

generation. Even the spark timing is advanced, BSHC and BSCO emission increases with increased level of EGR rate. Under the low load, BSHC emission shows sudden increase with high EGR rate because slow combustion speeds lead to partial burning or misfire that produces unburned hydrocarbon.

Figures 9~12 show the trends of COV_{imep} , cylinder pressure, power and BSFC according to the change of spark timing and EGR rate at 2400rpm and 3000 rpm. As EGR rate is increased, the spark timing for minimum COV is advanced. COV_{imep} is increased as applied EGR rate is increased while it is decreased as spark timing is advanced. Flame propagation speed is decreased as EGR rate is increased. If spark timing is advanced, however, increased time gives fuel mixture more time of combustion. But if EGR rate goes over a limit value, it would be much more difficult to maintain stable combustion by controlling spark timing. If the shape of combustion chamber and the design of intake valve and port can be modified for fast-flame propagation, the amount of EGR increases without sacrificing engine stability.

$\theta_{P_{max}}$ (ATDC) was retarded as EGR rate became higher at the same ignition timing, because

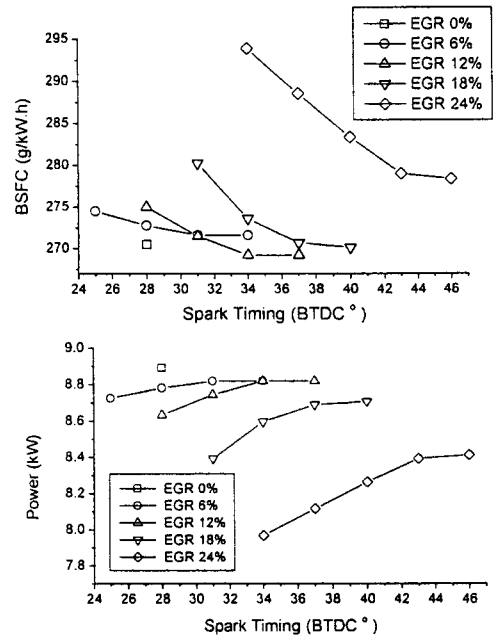

Fig. 10 Effect of EGR rate on brake power and BSFC (2400rpm, I.D. : 5.81msec)

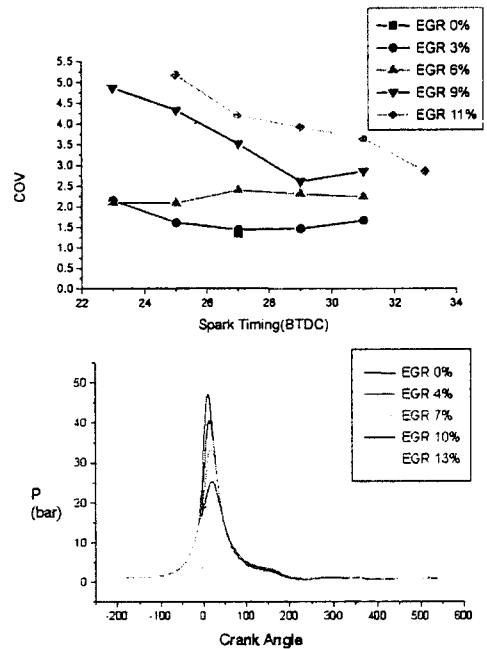

Fig. 11 Effect of EGR rate on COV and cylinder pressure (3000rpm, I.D. : 9.27msec)

increase of EGR rate leads to lower flame propagation speed. The value of P_{max} decreases in

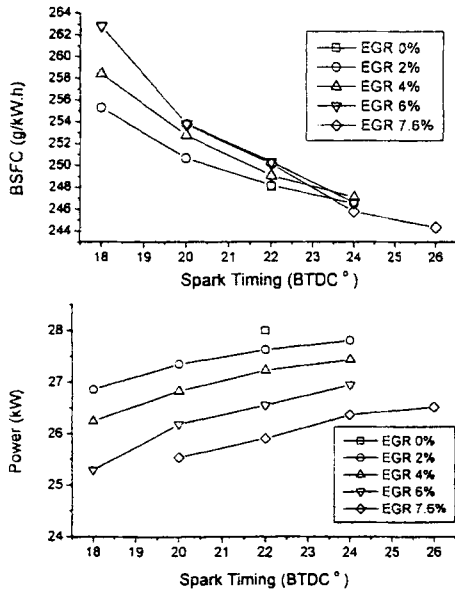

Fig. 12 Effect of EGR rate on brake power and BSFC (3000rpm, I.D. : 9.27msec)

proportion to EGR rate, and increases as spark timing is advanced. With application of EGR, P_{max} could be lower and NOx emission from engine could be reduced effectively.

BSFC is decreased if spark timing is advanced until MBT due to the increase of engine power. BSFC is decreased more in the case of optimum EGR rate than in the case without EGR. But if EGR rate is increased more than optimum point, BSFC becomes larger. As EGR rate is increased, the spark timing for minimum BSFC is advanced.

The engine power decreased with EGR rate, and increased as the spark timing is advanced. As EGR rate increases, the spark timing of maximum engine power would be advanced. This means that optimum spark timing for engine power and fuel economy depends on the EGR rate.

Figures 13 and 14 show the effect of hot and cooled EGR rate on engine performance, NOx, THC and CO. Cooled EGR with a heat exchanger was controlled about $100 \pm 5^\circ\text{C}$. If injection duration can be adjustable, the torque of engine with cooled EGR is usually higher than that with the hot EGR due to the increase of air and fuel mixture with same EGR rate. The reason is the decrease of gas temperature and specific

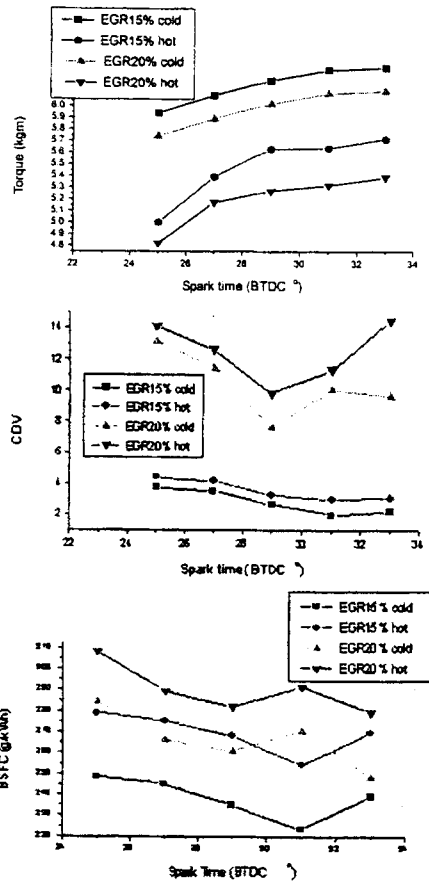

Fig. 13 Effect of hot and cooled EGR rate on Torque, COV and BSFC (2000rpm, I.D. : 6.27msec)

volume of cooled EGR, which make air and fuel mixture into cylinder increased. In cooled EGR, COV_{imep} is lower than that of hot EGR but the difference is relatively small. The reason is that combustion instability is reduced by low EGR gas temperature. BSFC with cooled EGR is lower than that of hot EGR due to torque increase. Therefore, considering engine performance, cooled EGR is better than hot EGR. Cooled EGR shows very small difference with hot EGR in NOx emission. In the case of cooled EGR, NOx emission is expected to be lower than that from hot EGR because of low gas temperature. But for warmed up condition, EGR temperature has a little influence on NOx emission because P_{max} changes small. HC emission follows similar trend

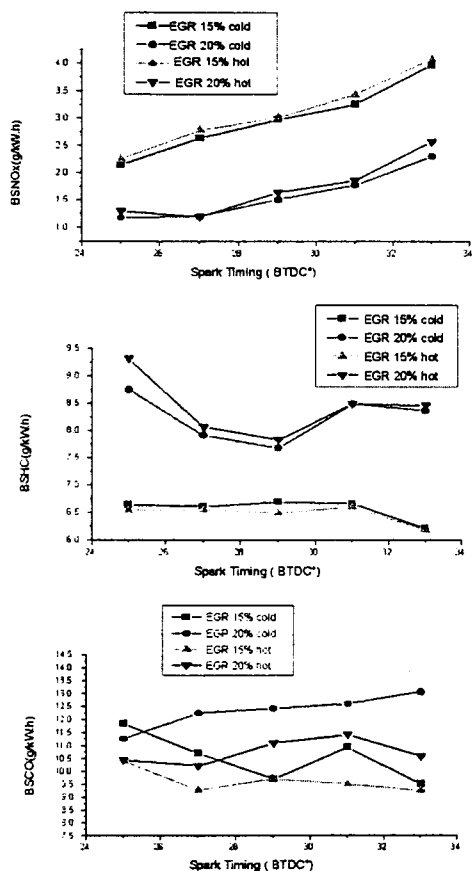

Fig. 14 Effect of hot and cooled EGR rate on NOx, THC and CO (2000rpm, I.D.: 6.27msec)

of NOx changes. But the CO emission of cooled EGR is higher than that of hot EGR due to the lower cylinder temperature with the cooled EGR.

Figures 15 and 16 show pumping work loss and gain by EGR. In EGR 4%, intake pressure gets higher during intake process and exhaust pressure gets higher as much as intake pressure. Therefore, the pumping work of EGR and without EGR do not change greatly. But, in EGR 15%, intake pressure increases greatly, while exhaust pressure increase a little. Therefore, pumping work would be decreased.

6. Conclusion

This study examined the effects of EGR on combustion stability, engine performance, NOx

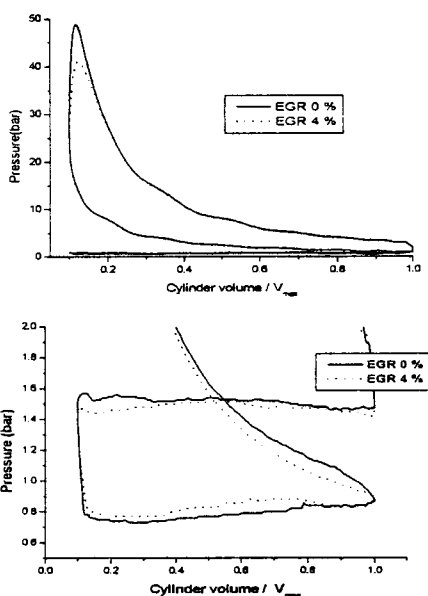

Fig. 15 Pumping work by EGR 4%

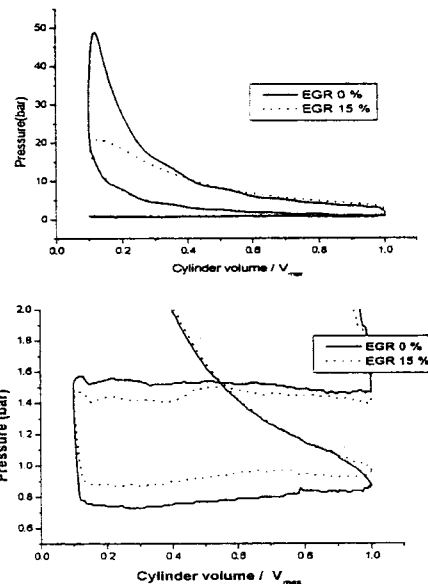

Fig. 16 Pumping work by EGR 15%

and the other exhaust emissions for gasoline engine. The experimental results are summarized as follows.

EGR could reduce the formation of NOx emission rate from 25.4% up to 89.6% with EGR on standard engine.

Although the power decreases with decreased

fuel supply, BSFC decreases with the effect of EGR except the case of excessive amount of EGR. BSFC is decreased due to increase of brake power as spark timing is advanced.

As EGR being applied, not only flame propagation speed but also the peak burned gas temperature and pressure were decreased. Therefore, ignition timing advance is required to minimize the power loss and to achieve the stable combustion.

COV_{imep} is proportional to applied EGR rate and is decreased as spark timing is advanced. Therefore, the spark timing of minimum COV_{imep} is advanced as EGR rate is increased

$\theta_{Pmax}(ATDC)$ is retarded by application of EGR, since flame propagation speed becomes lower due to EGR rate increase. P_{max} decreases in proportion to EGR rate, and increases as spark timing is more advanced.

When EGR is applied, brake power is reduced in inversely proportion to EGR rate, and is increased as the spark timing is more advanced. However, if spark timing is advanced further from the MBT, brake power decreases.

When cooled EGR is applied, the engine performance improves but emissions get worse or change little.

References

- Duleep, K. G. and Meszler, D., 1996, "Emission Control Technology to Comply with FTP Revisions," SAE paper 961115.
- Watson, H., 1997, "Ultra Lean Burn-The Future for High Efficiency Low Emission Vehicles," *Proceeding of the 4th Asian-Pacific International Symposium on Combustion and Energy Utilization*.
- Neame, G. R. and Gardiner, D. P., 1995, "Improving the Fuel Economy of Stoichiometrically Fuelled S. I. Engines by Means of EGR and Enhanced Ignition A Comparison of Gasoline, Methanol and Natural Gas," SAE paper 952376.
- Hacohen, J., Ashcroft, S. J. and Belmont, M. R., 1995, "Lean Burn Versus EGR S. I. Engine," SAE paper 951902.
- Heywood, J. B., 1988, *Internal Combustion Engine Fundamentals*, McGraw-Hill Book Company, pp. 419~427.
- Han, S. B., 2001, "Investigation of Cyclic Variations of IMEP Under Idling Operation in Spark Ignition Engines," *KSME International Journal* Vol. 15, No. 1
- Kalghatgi, G. T., 1987, "Spark Ignition, Early Flame development and Cyclic Variation in I.C. Engines," SAE paper 870163.
- Dai, D. and Davis, G. C., 1987, "Diluents and Lean Mixture Combustion Modeling for SI Engines with a Quasi-Dimensional Model," SAE paper 952382.
- Park, S., Chung, Y. and Park, J., 1998, "The OBD-II System in the Hyundai Accent," SAE paper 982551.